

# Spare Parts and Modernisation Guide

**FUEL SUPPLY SYSTEMS FOR PISTON ENGINE POWER PLANTS**

---

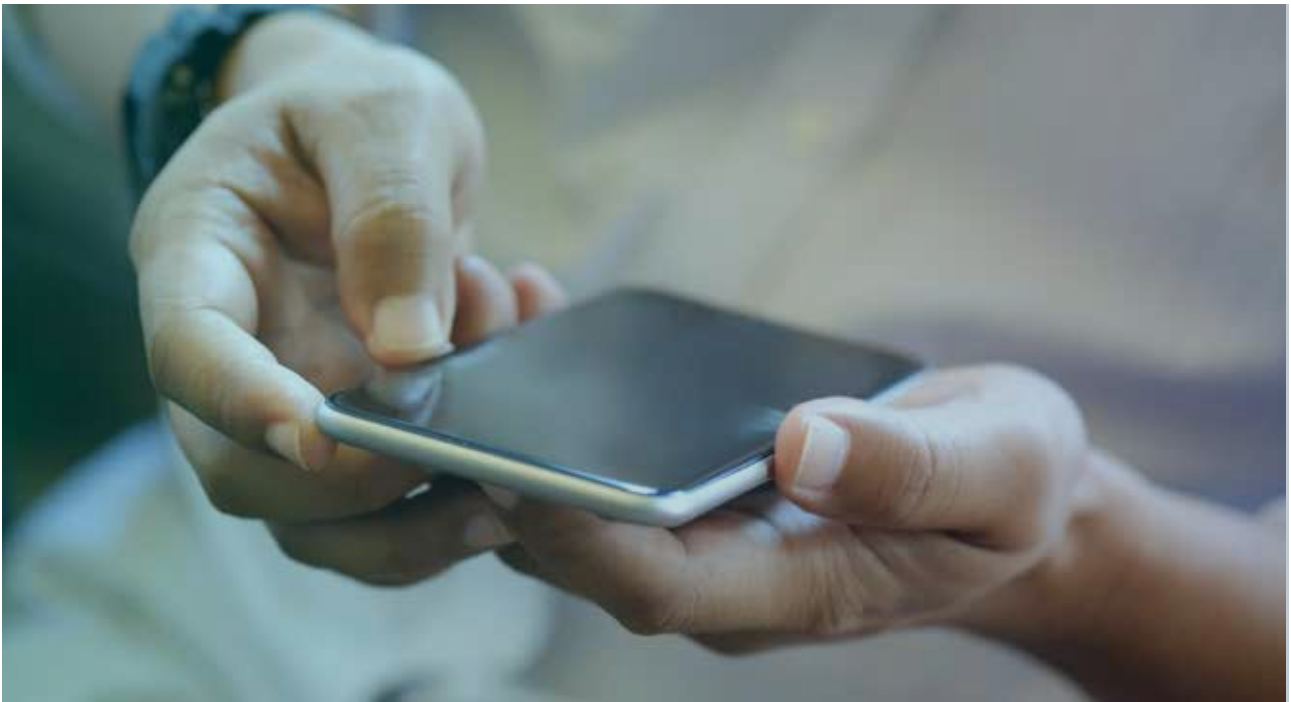



# How to use this guide

At Auramarine, we enable you to avoid the time consuming and laborious process of locating specific parts for a fuel system. All we require from you is the following information:

- Fuel supply unit serial number (if Auramarine)
- Previous part type
- Required values, such as flow rate, filter mesh size, etc.
- Part code (from Auramarine fuel supply unit part list)

## **IMPORTANT:**

The full Auramarine spare part inventory comprises of thousands of spare and wear parts. This catalogue therefore serves as a brief overview to our spare and wear part offering.

## **For quotations and support:**

- Send us an e-mail at: [after.sales@auramarine.com](mailto:after.sales@auramarine.com)
- Call us: +358 20 486 5030
- Fill in the contact form on our website (scan QR code below)
- Get in touch with our representative network as listed on our website [www.auramarine.com](http://www.auramarine.com).





# Contents

<b>How to use this guide .....</b>	<b>3</b>
<b>Critical components for operational safety .....</b>	<b>6</b>
<b>Spare and wear parts for overhaul and maintenance .....</b>	<b>10</b>
Customised spare part kits for planned maintenance.....	11
<b>Spare parts .....</b>	<b>12</b>
Electric components .....	13
Filters .....	15
Flowmeters .....	18
Gauges and indicators .....	21
Heat exchangers .....	22
Electric motors .....	23
Pumps and accessories.....	24
Valves .....	26
Viscometers .....	28
<b>Modernisation services based on your needs .....</b>	<b>29</b>
Electrical components and control optimisation for improved system performance.....	30
Filtration upgrades for enhanced engine protection .....	31
Importance of fuel pump compatibility .....	33
Flow meter upgrades and retrofits .....	34
Viscometer modernisations .....	35
Additional or replacement booster units.....	35
<b>Auramarine general spare part sales terms and conditions.....</b>	<b>35</b>

# Critical components for operational safety

Power plants are essential in supporting our global infrastructures; generating vital electricity for the populations they serve. Auramarine products help power plants to operate as efficiently and effectively as possible by performing critical fuel supply roles. Through selecting the most suitable parts, the service life of a power plant can not only be extended but run without technical disruption.

## Solutions to suit every station

Auramarine units are used for pumping, filtering impurities, heating and cooling, viscosity control, and many other functions at piston-engine operated power plants, and power stations, running on a variety of fuels, such as heavy fuel oil (HFO), light fuel oil (LFO), crude oil, biofuels, or gas. The units ensure that the fuel reaches the engine clean, at the optimum pressure and temperature and in accordance with engine maker's specifications.

With experience from approx. 2000 units delivered to power plants and stations globally we are committed to ensuring that your fuel supply system delivers the best operational safety and performance

In addition to fuel supply systems and components, we also deliver parts and units for lubrication and cooling purposes.



**fuel pressure**

**fuel temperature**

**fuel filtering**

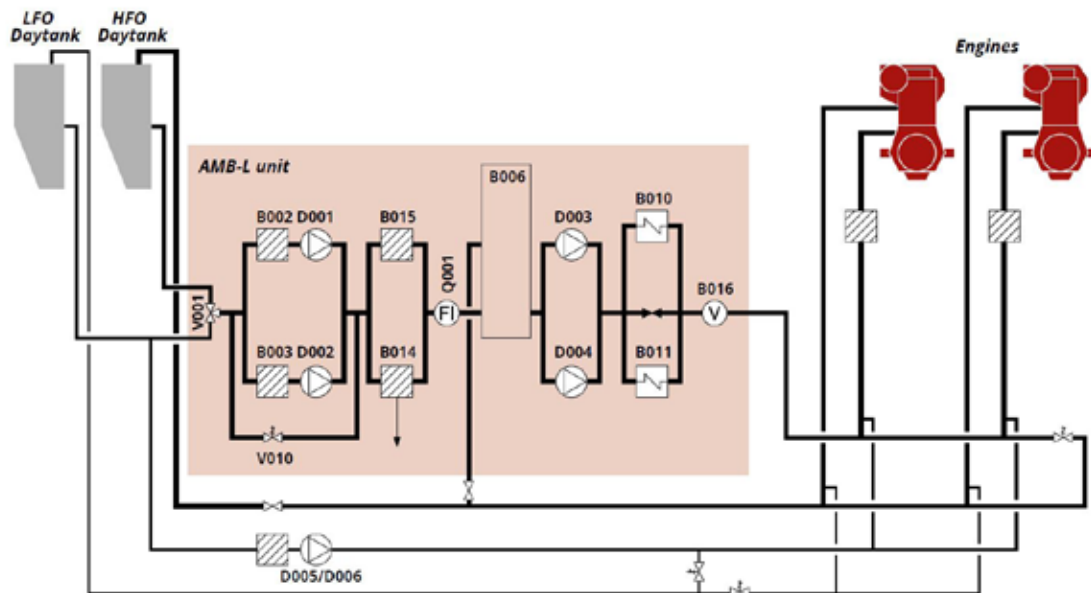

## Typical fuel supply system components and options

**HFO/LFO 3-way changeover valve, V001** for selecting fuel and flushing the system. The changeover valves and feeder pumps can be ordered as separate units. Manual or remote controlled

**Suction strainers B002, B003** for protecting the pumps

**Feeder pumps, D001, D002** for pressurising the system with fresh fuel according to the consumption of the engines, equipped with an automatic stand-by function. Magnetic or mechanical couplings

**Pressure control valve V010** for maintaining constant system pressure at different loads. With or without bypass

**Automatic filter with bypass filter, B014, B015** for removing impurities from fuel oil and indication of failures in purification system, equipped with automatic cleaning and pressure difference indication. Sizes: 34 / 25\* / 10\*  $\mu\text{m}$  in cold side, 48 / 34 / 25\*  $\mu\text{m}$  in hot side (\*certain fuel types and flows call for a larger frame)

**Flow meter Q001** for indicating fuel consumption. With local totalizer and output signal. Available as mass or volumetric type.

**Mixing tank B006** for mixing the return fuel from the engines with fresh fuel and for compensating for temperature and pressure changes. Manual or automatic deaeration

**Booster pumps D003, D004** for further pressurising and circulating fuel to the engines, equipped with an automatic stand-by function. If needed, an own circulating pump can be delivered for each engine. Magnetic or mechanical couplings

**Fuel heaters B010, B011** for heating the fuel oil to injection viscosity, controlled via viscometer. Steam heating (SS), Thermal oil heating (TT) or Electric heating (EE)

**Viscosity control system B016** for measuring the fuel viscosity and controlling the power of the heaters to maintain constant injection viscosity, secured by a temperature controller

**One or two LFO pumps D005, D006** for a separate LFO

If a separate feeder unit is ordered then the booster unit does not include feeder pumps

## Auxiliary units

### Feeder unit (AMF)



The Auramarine feeder unit (AMF) is designed to supply fuel oil to engines or HFO booster units. The unit is composed of two main elements: an operating pump and a standby pump, with the standby pump used as the reserve pump for service periods. The standby pump can be delivered as a separate module, if required.

### Lubrication unit



Auramarine's Lubrication Oil Units are primarily used for pumping and filtering. The Lubrication Oil Units can also be used for the cooling of lubrication oil when necessary. The units are easy to use and can be tailored to meet the lubrication oil handling needs of your specific system configuration.

### HT-water preheating unit (APU)



APUs are typically used to keep the engine block warm for easy start-ups and to avoid heat tension in the engine. Auramarine's preheating units (APUs) heat the water used in an engine's high temperature (HT) water system. The heat is generated via steam or burning thermal oil. APUs are equipped with an associated HT-water circulation pump, which provides a continuous flow of heated water. The water temperature is kept constant by a built-in self-actuating thermostatic controller located in the unit. APUs can be remotely controlled or operated from a control cabinet mounted on the unit. For heat adjustment, thermostat valves or PID-controlled valves can also be supplied for the HT-water system needs, depending on where the HT-system's excess heat is directed to. Additional pressure gauges and a thermometer are available as optional extras.



# Customer-specific solutions with AMB-L -series



Auramarine fuel supply units for power plants are configured to meet each power plant's requirements. Configurations can comprise separate feeder and booster units, a combined feeder-booster unit, a steam-based, thermal oil or electric heating system, LFO cooling unit, gas valve units, flowmeters, filtering or viscosity control and automated heating.

## Main features

- Can be extensively customised to meet all fuel system-specific requirements
- Proven reliability and safety from shell- or plate type heaters and separate viscosity and temperature controls
- Fast, easy installation delivered through a compact design and versatile connections
- Easy operation: all important displays and instruments are visible at a glance
- Long and extremely reliable service life from quality components, carefully chosen materials and advanced manufacturing

## Sizes:

The L-series is available in eight different size classes, according to the total engine power to be served. The number refers to the engine power in MW and the letters that follow represent the heater type. Several units can be combined to reach the specified power output.

### AMB-L 12...26

- Maximum power serviceable: 25MW
- Dimensions, including service space: minimum 3.60m x 2.20m
- This frame size can expand depending on optional additional features
- 

### AMB-L 36...60

Maximum power serviceable: up to 60MW  
Dimensions, including service space: minimum 5.00m x 2.60m.  
This frame size can expand depending on optional additional features

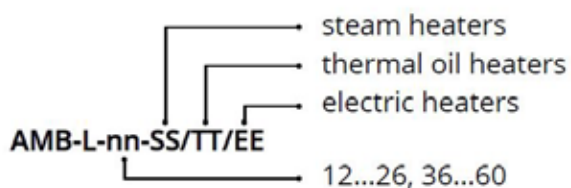

# Spare and wear parts for overhaul and maintenance

Investing in the most suitable spares inventory is vital to ensure minimal fuel system downtime and smooth spare parts' management. The parts are delivered with the required documentation (e.g. EC declaration of conformity).

## Renewals due to normal wear

Typical parts include pumps, viscometer packages, renewal or overhaul of filter units, heater overhaul, or replacement due to wear. Electric cabinets, or electric cabinet components, can also be tailor made based on unique customer circumstance.

Auramarine parts are tailored to complement your equipment and ensure continued peak performance. The spare part deliveries are supported by inspections, preventive maintenance, as well as on demand maintenance and repairs.

## Modernising or re-locating

The relocation of a power plant can provide protection of your original investment while utilising the capacity of the plant in a location where the operating environment is more favourable.

## Upgrade options

In the circumstance that the relocation of a plant is considered, it is of value to determine if there are either worn parts that need to be replaced or if the system components and auxiliary equipment could benefit from modernisations.

We suggest a holistic approach to evaluate whether it is of greater value to replace individual parts or a whole unit.

In many cases replacing the fuel supply unit has resulted in a more cost effective and time efficient long-term solution as it requires a lower investment cost and reduced overall workload.

Modernisation can help to:

- Analyse which wear parts need to be replaced
- Provide auxiliary equipment for a quicker engine start-up (pneumatic start-up)
- Add unloading/offloading units depending on the new location's infrastructure and storage tanks. Transfer units also available
- Provide the necessary number of feeder pumps, in way of storage tanks, to supply fuel to the whole plant, and engine specific booster pumps inside the plant
- Deliver HT/LT water pumping systems if the new setup requires.



# Customised spare part kits for planned maintenance

Our systems are carefully designed and manufactured with strategic backups to ensure the smooth running of operations and avoidance of downtime. However, you should still retain an optimised set of critical spares at the power station to effectively safeguard against all eventualities.

We ensure this is a simple and straightforward process with our customised spare part kits. Kits can be individually tailored to match a power station's specific requirements to maintain an

optimal wear parts inventory at all times. This solution is configured through our specialist software, which intelligently identifies a tailored spare parts kit for a specific fuel supply system over a given period.

The spare part kit listing is free of charge and tailored to ensure minimal fuel system downtime and smooth spares management.

Contact our team for a free trial:

[after.sales@auramarine.com](mailto:after.sales@auramarine.com)

Here is what your customised spare part kit could consist of:

## Spare part selection for feeder-booster AMB-L-15-S-LT-P

Item code	Position	Ordering code	Part No	Description	PCS	Maintenance rate
CM002282	B003	CM002282	1	Strainer screen Strainer screen, 400 um	1	1 year
M020122	B007	AFM000816	3	Strainer Strainer screen	1	2 year
M003295	B010	AFS000618	4	Heat exchanger, tube Gasket set, heat exchanger	1	1 year
M021327	B012	AFS000907	SET1	Heat exchanger, Plate Gasket set, heat exchanger	1	5 year
S020031	B014	AFM000550	6	Filter assembly Candle element	6	1 year
		AFS000795	SET1	SP2 reserve gasket set, filter	1	1 year
M020117	B023	AFM000486	3	Strainer Strainer screen	1	2 year
M000030	D003	AFS000814	G053	Pump, screw Minor kit	1	1 year
M000028	D007	AFS000817	G053	Pump, screw Minor kit	1	1 year
CM003725	V013, V014, V015	CM003725	1002	Valve, ball Ball valve, DN40	1	
		AFS000858	SET1	Gasket set	1	2 year
CM003726	V016, V020, V024, V025, V026, V036, V037, V038, V040, V041, V042, V044, V048, V053, V054, V055, V056	CM003726	1002	Valve, ball Ball valve, DN50	1	
		AFS000859	SET1	Gasket set	1	2 year

# Spare parts



# Electric components

Auramarine provides electrical components to replace, repair, and modernise existing components across the marine and power industries. The reliable availability of electric spare parts is becoming increasingly important in ensuring the safe and reliable running of fuel supply systems. Our global and rapid delivery service ensures customers receive spare parts that are tailored to fit specific fuel supply systems in a short delivery time wherever they are in the world.

Likewise, if a replacement electrical component requires updated drawings and documentation, Auramarine will provide support by supplying design details for any new set-up and submitting drawings and documentation as necessary. We also provide complete control cabinets and starter panels.



Control logic for automatic filter and heater



Frequency controllers

## NOTE:

If you notice any abnormal automatic filter function, e.g. frequent "filter clogged" -alarms, please contact Auramarine for program update.



Pressure switch



Pressure transmitter



Sensor PT100



Temperature controller



Time relay



Viscosity controller

In addition to these components, a wide range of parts are available upon request:

- Contactors
- Switches
- Signal lamps
- Temperature contactors



# Filters

Filters need to be carefully selected based on the fuel in use and engine maker's specifications to prevent damaging wear and tear across your engine components.

Typical filter spare parts comprise of gaskets, O-rings, candle elements, and pressure switches.

We also provide quality filters and filter spare parts for third-party fuel supply units.

Contact our team to find out more on our spare



Air escape aggregate



Candle element



Coil for solenoid valve for 110 VAC or 230 VAC



Connector plug for solenoid valve



Control disc for 6.72 filter

ts services: al



Cover for air escape aggregate



CPU for filter



Filter, available as automatic or by-pass filter



Filters, filter elements



Filter disc for 6.23 filter



Filter element, by-pass type



Filter element for 6.23 filter



Filter element, by-pass filter



Filter element, by-pass filter



Float for air escape aggregate

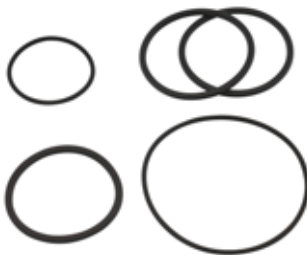

Gasket sets, various



Gasket sets, various



Installation frame/drip tray for additional filter





Limit switch, ATEX approved upon request



Limit switch, ATEX approved upon request



Multi-mantle element for duplex filter



Nozzle for air escape valve



Pneumatic actuator

**Filtration upgrades**  
For filtration upgrades, please see Filtration upgrades for enhanced engine protection on page 31.



Pressure indicator shut-off ball valve, brass AFM0



Pressure differential switch indicator



Safety valve for automatic filter



Solenoid valve



Solenoid valve set for type 6.23

# | Flowmeters

It is necessary to continuously measure and document the consumption of fuels at power plants to maintain efficiency and minimise fuel costs.

## Mass flow meters

Mass flow meter transmitters are built with an advanced architecture and provide a wide variety of I/O and application flexibilities, making them the top choice for compact integral mounting.

If fuel is purchased in metric tonnes, it is easier to measure fuel consumption in terms of mass weight. The majority of fuel mass flow meters use a laterally vibrating, curved tube mass flow meter which also measures the density of the fluid.

This fuel mass flow metre design provides excellent accuracy for both low and high fuel flows and is especially beneficial when multiple fuels are in use. Mass flow meters always provide comparable results between fuels.

- Well-known brands of highly accurate mass volume flow and density measurement for applications that require a compact, drainable design
- Unlikely to stick and provides density reporting
- Excellent accuracy and reliability in power plant environment
- Auramarine offers a range of flow meters from trusted brands for various types of needs, e.g. Emerson, Promass Endress Hauser

## Volumetric flow meters

The majority of volumetric flow meters are comprised of moving parts which typically consist of either wheels and/or screws. The volumetric flow meters provide a local reading, pulse signal and/or an mA signal, and are designed to be easily operable and exceptionally user friendly. The functionality is easy to monitor, which means any faults can be rapidly detected and simple repairs can be, in most cases, carried out on site.

- Positive displacement principal
- Electronic display of total and resettable volume and actual flow rates
- Adjustable analog (mA) and pulse output signals
- Auramarine offers a range of flow meters from trusted brands for various types of needs, e.g. Aquametro and VAF

## How to order?

To ensure that you receive the right type and size of flowmeter, contact us (see page 6) and inform us of one or all of the below specifications:

- Serial number of your fuel supply unit (if Auramarine)
- The type of your current flow meter given on the part
- The item code on the fuel supply unit part list (available on board)
- The required flow rate for the new flowmeter
- Auramarine can help to find the best fit by reviewing your fuel supply system's measuring and reporting capabilities and needs



**Mass flow meter (Emerson).**

Photo courtesy of Emerson



**Mass flow meter (Endress Hauser)**



**Volumetric flow meter: Aquametro, VAF**



**Volumetric flow meter Aquametro**

## Flow meter spare parts



Accessories,  
Spare electronic display



Drivers



Inlet filters

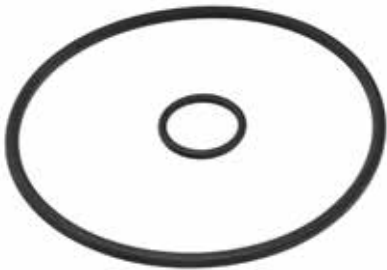

O-ring set, VZO 40



Roller counter



Rotary pistons

In addition to these components, a wide range of parts are available upon request:

- Gaskets
- Internal parts for flowmeters
- Measuring parts
- Spare electronics
- Separating plates

### Flow meter upgrades

For Flow meter upgrades,  
see page 34

# | Gauges and indicators



## Pressure gauges Thermometers

Make sure that you choose a pressure gauge that meets the pressure range requirements of your current or modernised fuel supply unit. Contact Auramarine to find the best suitable parts for your system.



# | Heat exchangers

Auramarine heat exchangers are available in shell design and in tube type design with U-tubes. The selection comprises of heat exchangers for steam, thermal oil, hot water or electrical heating. ATEX heaters are also available upon request.

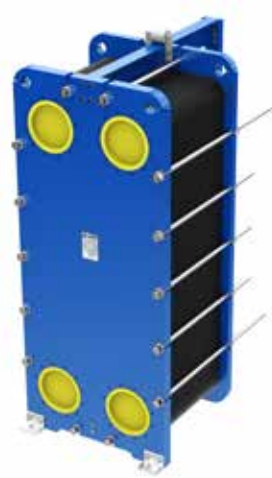

**Plate type heat exchanger (for cooling)**

In addition to complete heat exchangers, a wide range of parts are available upon request:

- Gasket sets
- Heating elements (electric)
- Safety thermostats
- Safety valves
- Tube inserts (steam, electric)

To ensure that you receive the right type and size of heat exchanger and other parts, please provide your fuel supply unit serial number. We can also provide quality heat exchangers and spare parts for third-party fuel supply units.



**Tube type heat exchanger, steam heating**



**Tube type heat exchanger, electrical heating**

# | Electric motors

Electric motors serve the fuel pumps on Auramarine fuel supply units. We offer electric motors both as spare parts and for modernisation.



Auramarine provides electric motors from the following brands:

- ABB
- Lönne
- Hoyer
- Kolmeks
- WEG
- others on request

We also provide pneumatically operated motors for emergency pump units.

In addition to motors, spare parts such as bearings and oil seals are also available. To ensure that you receive the right type of spare parts, please provide us with your fuel supply unit serial number. We can also provide quality spare part motors for third-party fuel supply units. Contact us and find out what we can offer for your equipment.



Fuel pump motor



Mechanical coupling for motor

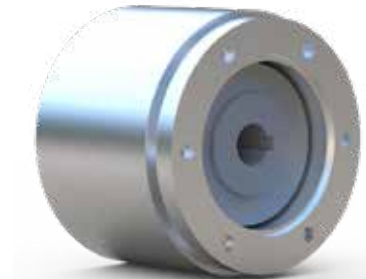

Magnetic coupling for motor

# | Pumps and accessories

We require the following information to help find the right parts for your fuel supply systems:

- Auramarine product code from item list
- Product information from name plate or serial number of the fuel supply unit
- Flow rate

The most frequently required wear parts for pumps are mechanical shaft seals, gaskets, and ball bearings (also available as ready "Minor kits"). We can also provide quality pump spare parts for third party fuel supply units.

Contact our team to find out more on our spare parts services: [after.sales@auramarine.com](mailto:after.sales@auramarine.com).

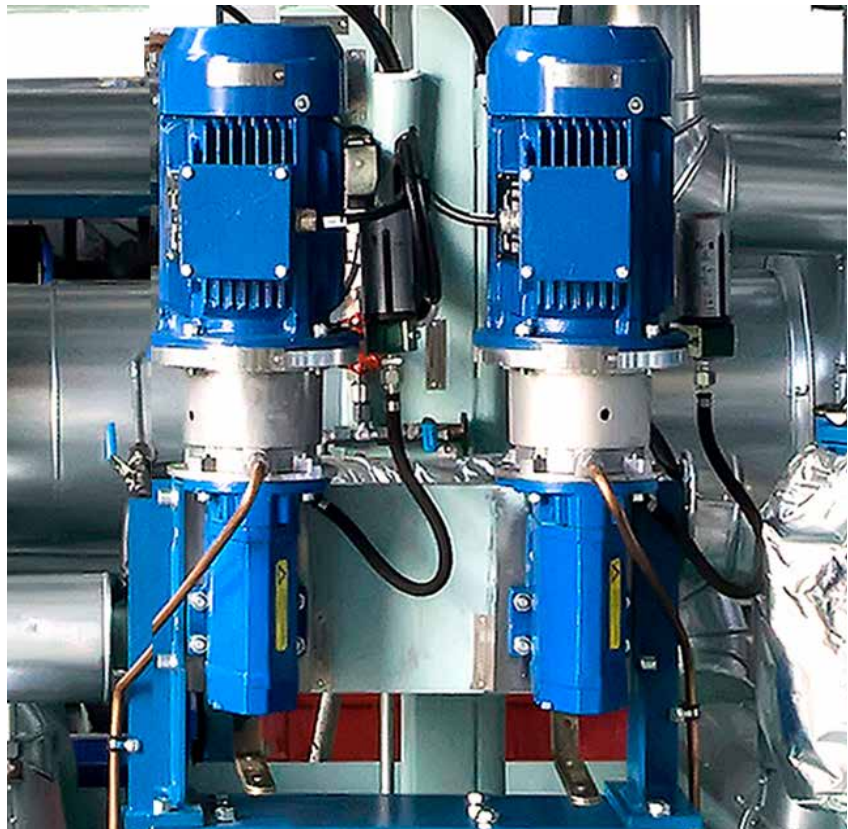

## **IMPORTANT:**

There are specific spare parts for each pump type. Always contact Auramarine for your right part.

## **Pump upgrades**

Pump upgrades may be necessary to e.g. increase pumping capacity when a fuel supply system is modernised or if the plant is re-located.



Screw type pump



Screw type pump



Screw type pump (High-pressure solution)





Centrifugal pumps and adapters



Balancing bush



Coupling, mechanical

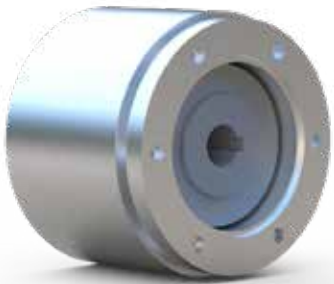

Coupling, magnetic



Distance sleeves



Distance washer



Joint spare part kits



Minor kits including gaskets, shaft seal and ball bearing

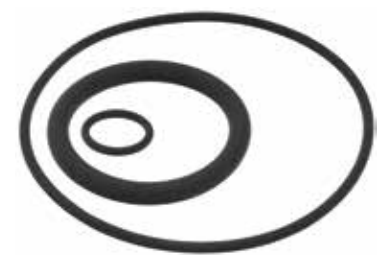

O-rings



Plug for deaeration



Secondary seals, various



Rotor set



Shaft seal spare part kit



Spare part kit valve element

# | Valves



Auramarine's spare valves and parts are carefully selected to meet the specific requirements of a fuel supply system. Our team can provide technical support to ensure you select parts compatible with your fuel supply system.

In addition to the system parts, our experts are ready to support with technical consultation and design, as well as drawing updates if system modernisations or modifications are required.

## **IMPORTANT:**

There are specific spare parts for each valve type. Always contact Auramarine for your right part. Please inform us the fuel supply unit serial number and valve type.



2-way valve



3-way valve



3-way valve



Temperature control system  
(various capillaries lengths  
available)



Control valve



Limit switch



Self-acting temperature  
controls with 2-port valves



Shut-off valve



Solenoid valve



Spare part repair kits, a wide  
selection with instructions

# Viscometers

The constant monitoring of fuel viscosity at an engine inlet is critical in ensuring continuous engine operation.

In addition to simply replacing a damaged viscometer, Auramarine can also assess whether upgrading a viscometer to the next generation will provide superior performance and additional value.

Auramarine provides spare viscometers from trusted manufacturers VAF and Emerson. The Emerson type viscometer comes as a full unit, while the VAF viscometer can either be purchased as a full unit, or with the sensor pendulum and the O-rings as separate items.



Viscometer, VAF



Viscometer, Emerson



Adapter kits

(includes Viscometer and adapter).  
Extended version of Adapter kit is available upon request. This is built case by case. Typical parts are e.g. steam control valve, PID controller and other accessories.



Flow tube



Housing, spare



Sensor pendulum



Viscosity controller

# Modernisation services based on your needs



# Electrical components and control optimisation for improved system performance

## Replacing electrical components

The replacement of electrical components is usually due to broken components, a system design change, or the replacement of obsolete or outdated components or systems. The reason for such replacements can either be functional or operational, and stem from the need to add control automation to ensure the work is streamlined and time efficient for plant personnel. This can also include the addition of control panels or control cabinets.

The replacement of electrical components often requires updated drawings and documentation. Auramarine can fully support with the design details for any new set-up and submit the drawings and documentation as necessary.

## Fuel heating and cooling

To ensure fuel systems remain fully functional when different fuel types and qualities are introduced to a system, control optimisation for existing heaters and coolers can be installed to improve system functionality and flexibility.

Auramarine offers an expert analysis of your existing fuel heating and cooling systems from an engineering and system process perspective, and can recommend the necessary improvements and, if required, also carry out



essential modifications.

Modifications are necessary throughout the lifespan of a fuel system. Our heaters can be designed to meet ATEX environment requirements. With a wide variety of heating and cooling arrangements, our control optimisation systems are tailored to fit each specific existing system to enable optimum performance.

## Early detection of system failures

Control optimisation can also be used to enhance troubleshooting capabilities. For example, properly optimised systems can detect system failures or deficiencies at an early stage, preventing malfunctions or instabilities, in fuel supply.

Optional features include viscosity and temperature control with signals to ECR and fuel consumption signalling (mA or pulse).

# Filtration upgrades for enhanced engine protection

Filters mitigate the risk of fuels causing excessive wear and tear to critical engine components.

Our filtration upgrades ensure that the maintenance team has better control over replacement schedules whilst following the latest engine manufacturer guidelines.

Fuel handling systems, such as feeder/booster units, are usually equipped with auto-backflushing filters, located typically after the feeder pump (also known as a supply pump). A filter replacement becomes necessary when the filter has reached the end of its lifecycle or in the case that it is not possible to find suitable spare parts for it.

To provide adequate engine protection, we recommend following engine manufacturer's specifications. An alternative to replacing existing filters, especially in the case of space constraints, is to add a second filter in front of the engine.

For a second separate filter we recommend our combined drip tray and installation frame. This ensures ease of installation and provides

required safety for the additional filter during operation. To be noted: the new filters may not fit in the same space as the previous filters, therefore suitability should be checked in advance. The need of piping work to be clarified in advance

## Suggested steps:

- An analysis of your current system's ability to cope with engine manufacturer's requirements
- Suggestions for the best possible technical options. In certain cases, the existing system has restrictions that call for a re-evaluation of the whole fuel handling process due to space constraints or control system issues
- Modification design, including upgraded specifications
- Quality components
- Support in incorporating modified items into your existing control systems.

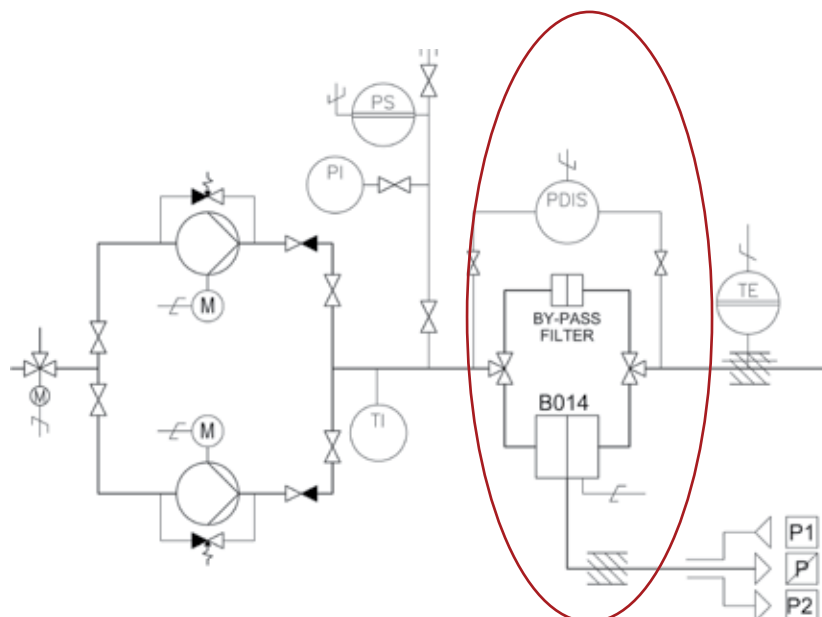

## Fuel-specific filtration solutions

The fuel handling process and the need for eliminating harmful particles in the fuel, for example, varies depending on the chosen fuel type.

With this in mind, the latest service letters and instructions from engine manufacturers should always be followed.

Residual fuels, such as HFO or LSHFO, typically contain catalytic fines, which have an abrasive effect on engine parts, and need to be removed before engine inlet.

For these fuels, we recommend fine filters, starting from 6 micron, either as a replacement for existing filters or as an additional filter in front of the engine. Although distilled fuels do not contain catalytic fines, Auramarine can still support you in finding the right filtration solutions.



Fuel filter



CPU for fuel filter



Installation frame/drip tray for additional filter



Filter elements



# | Importance of fuel pump compatibility

Modernisations may be necessary to ensure pumping capacity and lubricity.

Typical situations include when the old pumps come to end of its lifecycle, when spare part availability for old pumps is poor or if the pump capacity needs to be increased. Capacity increase is needed, for example, when engine power is increased and subsequently an increased fuel flow rate is required to ensure the continued operation of the engine.

Our expert service engineers can carry out the fuel pump compatibility check for you. Likewise, Auramarine will deliver the correct parts, carry out the assembly and test the pump function and performance if an upgrade is required.

## What should be checked?

For screw pumps, correct clearances and dimension measurements are important for maintaining the required pumping capacity. Pumps should be inspected for signs of wear and tear, including checking the condition of the gaskets. Screw dimensions should also be investigated to ensure lubricity. Practical steps include an investigation of the pump's properties to ensure it meets the requirements set by new fuels. If the documentation is not available, a picture of the pump name plate can often provide our engineers with sufficient information.

- **clearances**
- **gaskets**
- **wear and tear**
- **dimensions**
- **lubricity compatibility**
- **documentation**

## Steps to maintain correct pumping capacity

In the case that your fuel pumps require replacement, we can support by defining the specification of a new pump and delivering pumps that are the correct size in terms of dimensions and capacity. Auramarine can also provide a fully updated fuel system piping and instrumentation diagram. Cost-efficiency and system flexibility are key considerations, throughout the entire modification process.

Mechanical pumps can be delivered with magnetic coupling as an option, which helps to eliminate possible shaft seal leakages.

An Auramarine, delivery will include all the necessary components to ensure a smooth implementation process. A typical delivery consists of the pump, the relevant instructions, as well as any additional technical support. Pump replacements may require minor changes to the plant's original pipework.

# | Flow meter upgrades and retrofits

Auramarine can provide support to improve fuel consumption measuring and reporting and enable reliable real-time measurement with high accuracy. Especially when existing flow meters become outdated and new flow meters are being considered.

## Upgrade options

### Replacement of volumetric with mass flow meters

Mass flow meter transmitters are built with an advanced architecture and provide a wide variety of I/O and application flexibilities, making them the first choice for compact integral mounting.

They provide mass volume flow and density measuring with excellent accuracy.

The dimensions of a mass flow meter are usually larger than the dimensions of a volumetric flow meter and therefore some piping modifications are typically be required.

### Upgrade of existing volumetric flow meters

It is also possible to combine the measured density information with the volumetric information. In certain cases, this can be the most cost-effective option. It has also been found that this approach can be as accurate as mass flow meters under normal operating conditions. It is also suitable for low or high flows. The upgrade requires certain re-cabling, engineering updates, and integration within the fuel handling system to ensure the continuation of effective operations.



Contact us to find the best fit for your fuel supply system requirements. We can review your fuel supply system's current measuring and reporting capabilities. Based on the review, we will recommend specific improvements to best support your power plant's needs.

# Viscometer modernisations

It can be challenging to source the correct spare parts, especially for older generation viscometers.

Our viscometer retrofit kit can solve this problem through ensuring that all parts are compatible. A typical kit can comprise of a housing sensor, an interface box, a control cabinet controller, and a steam regulation valve amongst other parts.

At Auramarine we tailor every retrofit kit to specifically fit your individual requirements, please contact us for a free consultation: [after.sales@auramarine.com](mailto:after.sales@auramarine.com).



# Additional or replacement booster units

In certain scenarios, it can be more cost-effective and time efficient to instead replace the whole unit.

Auramarine has experience from feeders and boosters, or feeder-booster unit deliveries for plant extensions, to replace damaged units and to fulfil additional capacity requirements.

This can also be the case for fuel unloading and transfer units.



## Auramarine general spare part sales terms and conditions

Find our Spare Part Sales Terms and Conditions on our website: [Auramarine / Lifecycle services / Auramarine Original Spare Parts](#)

**Auramarine is your trusted fuel systems expert for marine and power industry. Our proud heritage stems from the founding of the company in Finland in the early 1970's. Since then we have delivered over 15 000 robust and reliable auxiliary systems to our customers all over the world, continuously aiming for superior service and customer value.**

**WE ARE THE PIONEERS IN FUEL SYSTEMS.**

ID 709448

**AURAMARINE LTD**

**P.O. Box 84 FI-20101 Turku FINLAND  
+358 20 486 5030**

**after.sales@auramarine.com  
sales@auramarine.com  
www.auramarine.om**

